



# Instructions for TREX™ TOTAL ROTARY EXTRACTOR



Please read before use.



Register your product at  
[http://www.mytee.com/  
support/register](http://www.mytee.com/support/register)

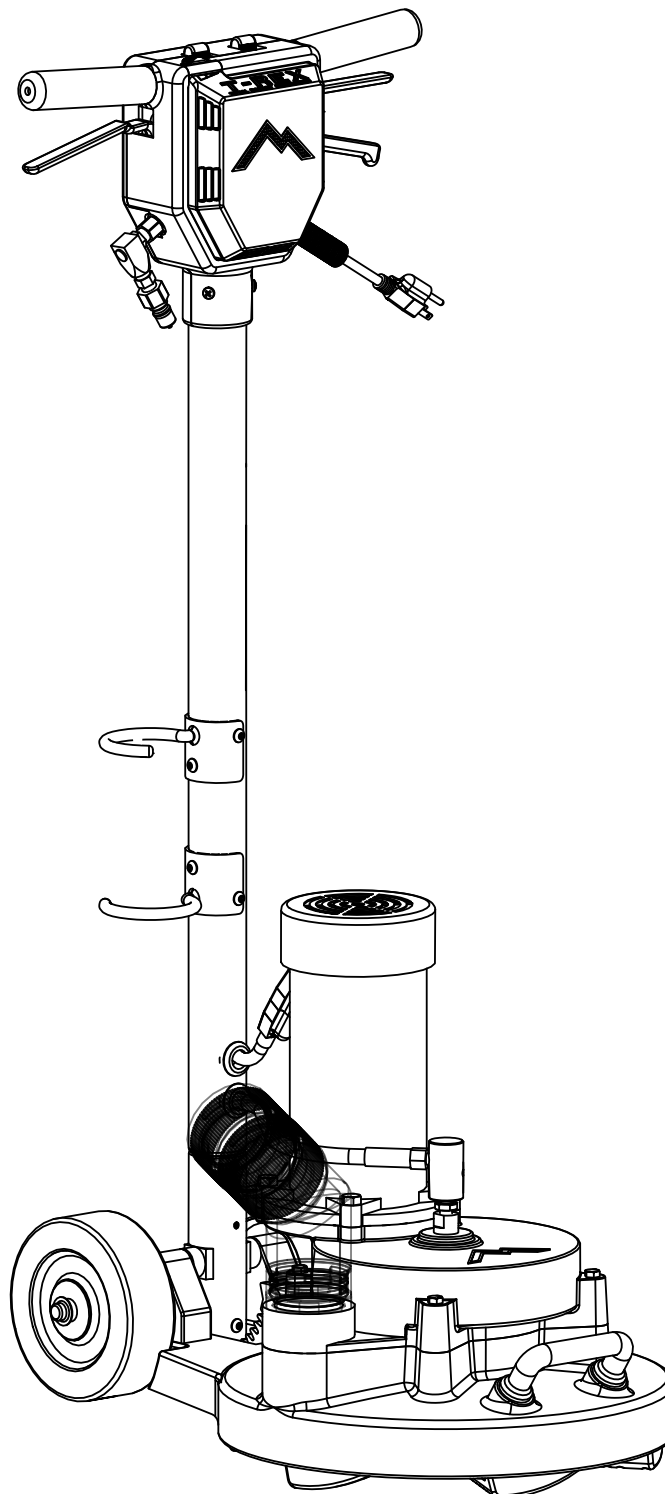

Set up p.2  
Parts & pricing p.8  
Wiring diagram p.10  
General & Maintenance information p.11  
TREX™ Accessories p.15

Model # \_\_\_\_\_

Serial # \_\_\_\_\_

Form # ADP-TREX

1-15

TREX™ FRONT

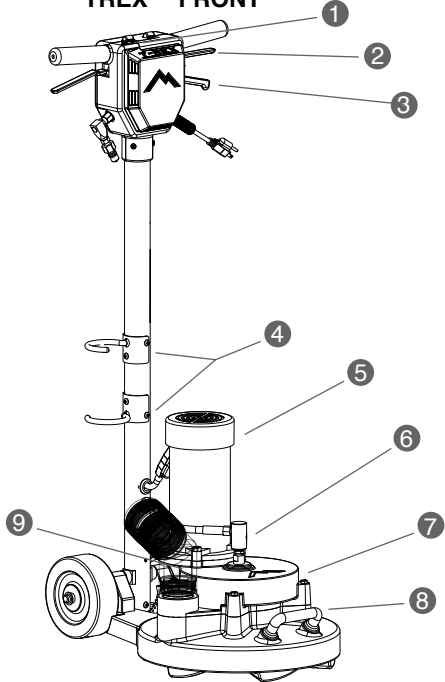

- 1. Speed Control Knob
- 2. Switch Lever
- 3. Handle Adjustment Lever
- 4. Hose Restraints
- 5. Motor
- 6. Rotary Union
- 7. Transmission
- 8. Lift handle
- 9. Clear View Cuff-Lynx™ Elbow

TREX™ BACK

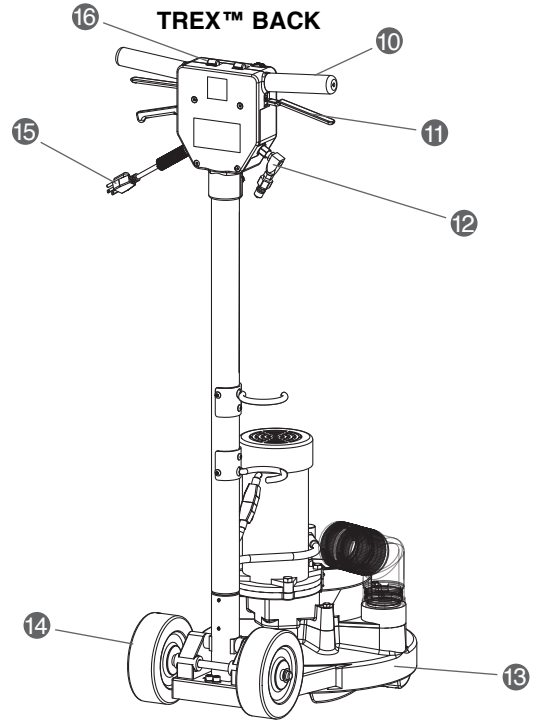

- 10. Handles
- 11. Solution Lever
- 12. 90° Quick Connect Swivel
- 13. Cleaning Head
- 14. Heavy Duty Wheels
- 15. Pigtail power cord
- 16. Safety Lockout

TREX™ ITEMS INCLUDED

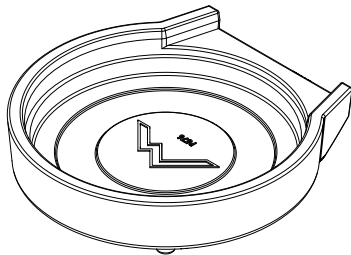

A916 - Head Protector

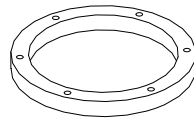

G014 - Felt Ring Seal

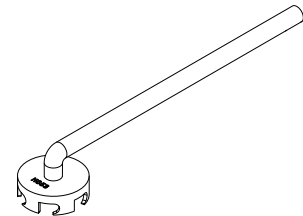

H053 - Head Removal Tool

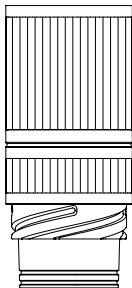

H136 - 2" Male Coupler Swivel

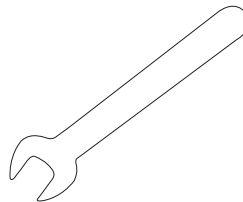

H051 - 5/8" Flat Wrench

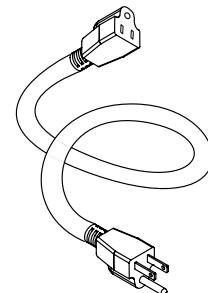

E617A - 25' Power Cord

**TREX™ HEAD COVER**

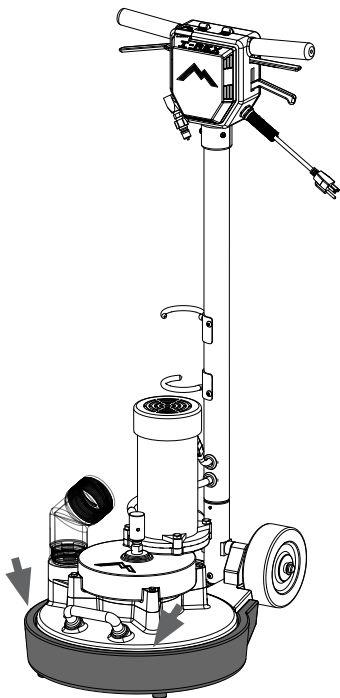

Head cover is protects the head from any type of damage. Simply press down on the head cover to remove. Apply cover when not in use.

**TREX™ CORD**

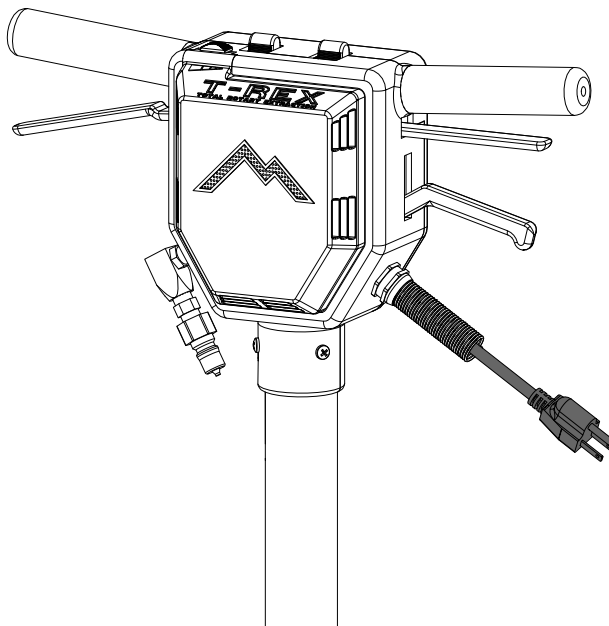

Connect pigtail plug to 25' power cord. Plug power cord into a grounded wall outlet.

**TREX™ VAC/SOL HOSE CONNECTIONS**

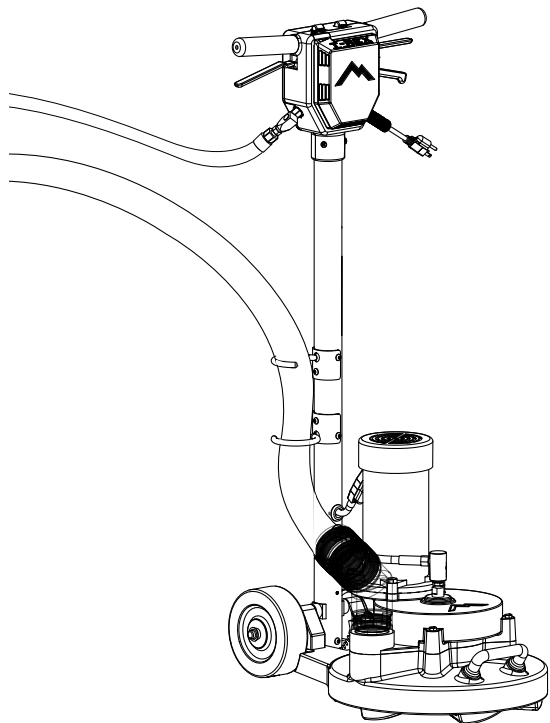

Connect solution hose from your extractor to swivel QD fitting on TREX™ handle. Also, connect vacuum hose from extractor to vacuum relief inlet on TREX™

**TREX™ ADJUSTMENT LEVER**

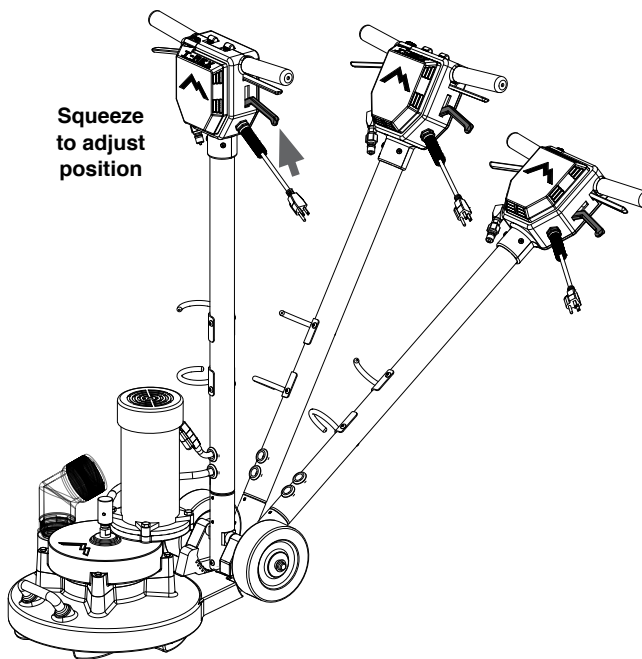

Squeeze to adjust position

The handle can be adjusted to any desired working position by simply squeezing the adjustment lever. Move the handle to the desired position, then release adjustment lever locking handle in place.

### TREX™ SAFETY SWITCH

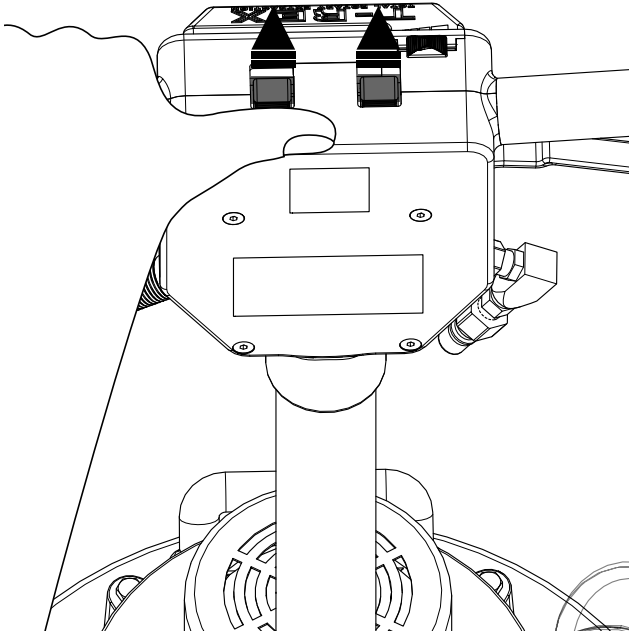

The handle must be lowered to the operating position before switching the machine ON. Disengage the safety switch lock by pushing it forward with either thumb.

### TREX™ ACTIVATION LEVER

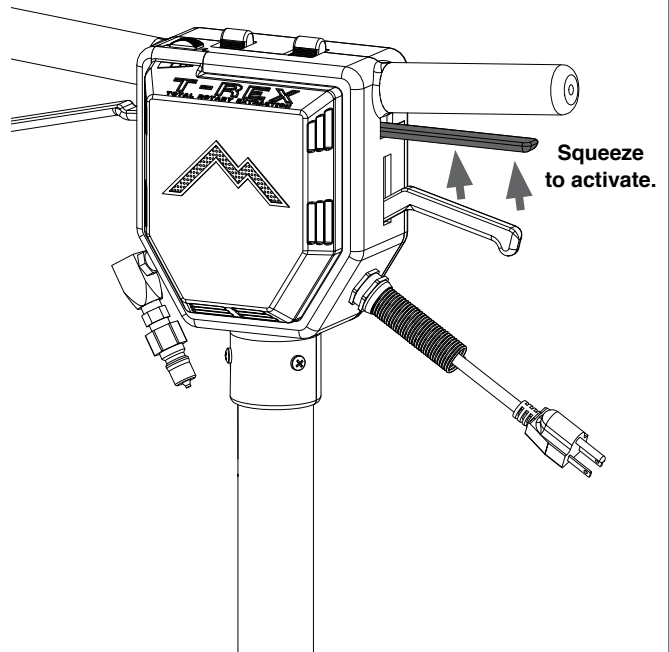

While holding the safety switch lock in disengaged position, squeeze the activation lever to operate machine. To stop the machine, simply release the lever.

### TREX™ SPEED ADJUSTMENT

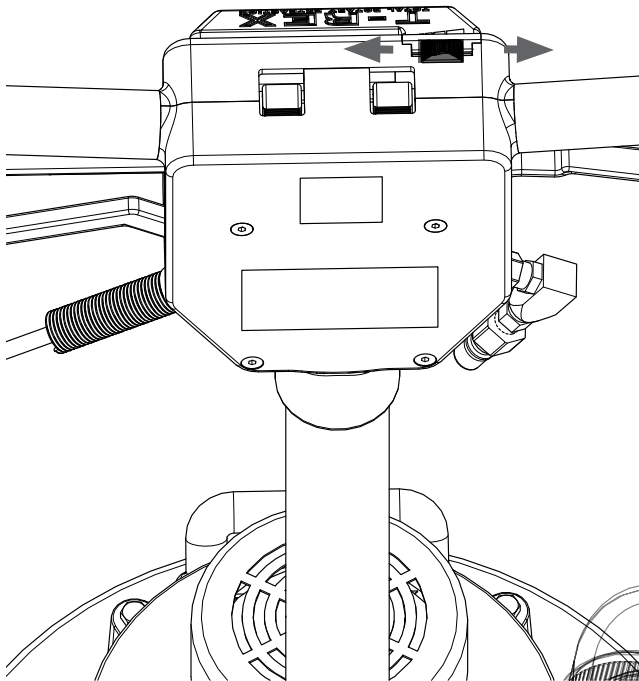

Located at the top of the unit is a speed adjuster. Unit adjusts from 80 - 160 RPM. Move to the left for a slower speed. Move to the right to speed up. Position to desired speed.

### TREX™ SOLUTION LEVER

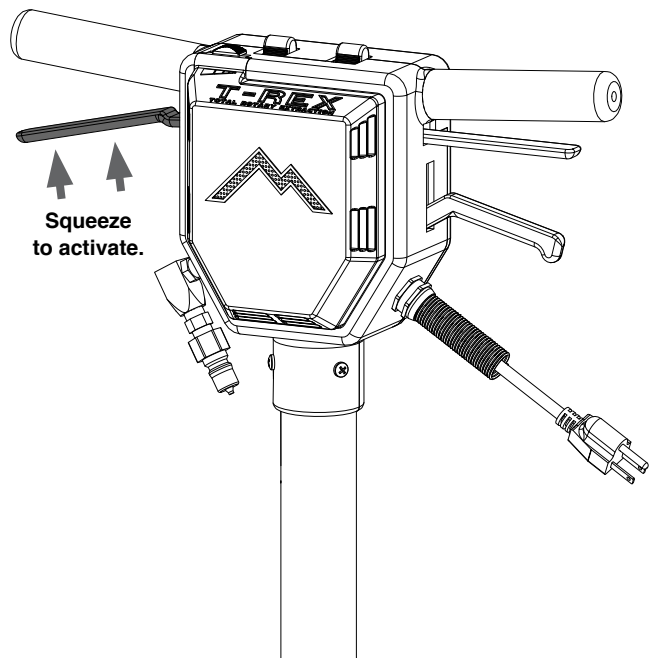

Squeeze lever for solution flow. PSI will be controlled by your extraction unit.



**ATTACHING TREX™ HEAD**

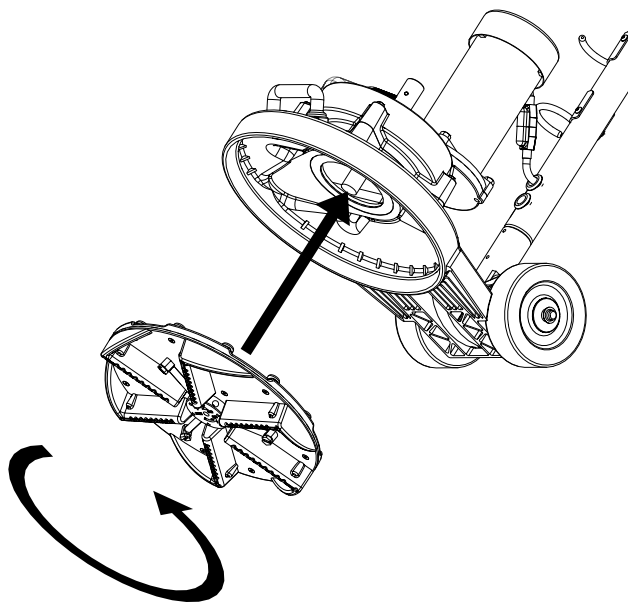

To attach the head, place the center piece of the head on the threaded piece located underneath, at the center of the TREX™. Once on, twist counter-clockwise.

**REMOVING TREX™ HEAD**

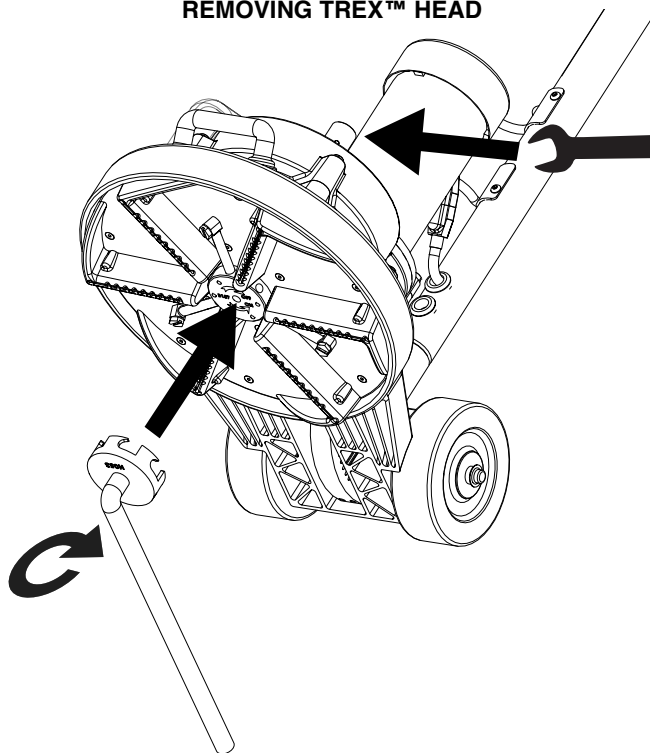

To remove, place wrench on rotary union and attach the head removal tool and twist clockwise.

**LUBRICATING VACUUM SEAL ON TOP OF HEAD**

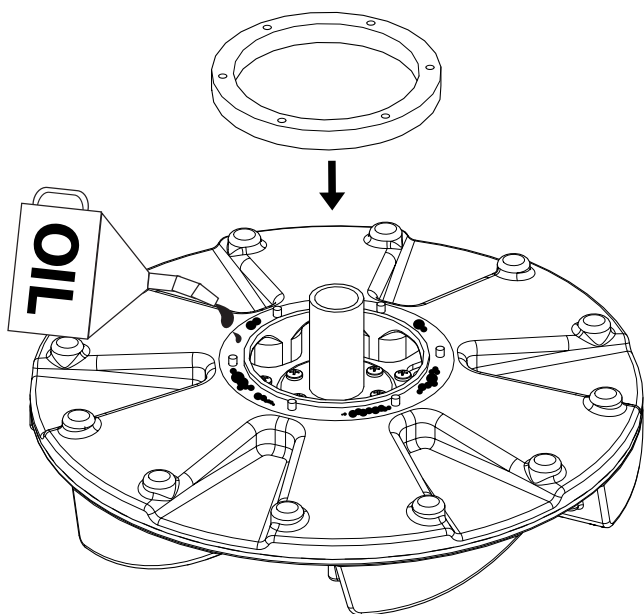

Lubricate the felt vacuum seal on top of the head with a quality, 30 weight SAE motor oil. In addition, add some drops to the seal seat.

**LUBRICATING FELT SEAL**

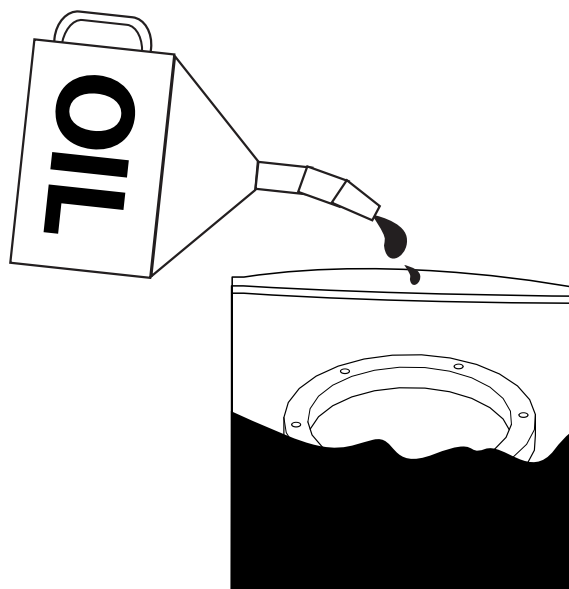

When it comes time to replace the felt seal, we recommend placing the felt seal in a zip lock bag along with some oil. Move the zip lock bag so that the entire felt seal is lubricated.

MANEUVERING YOUR TREX™

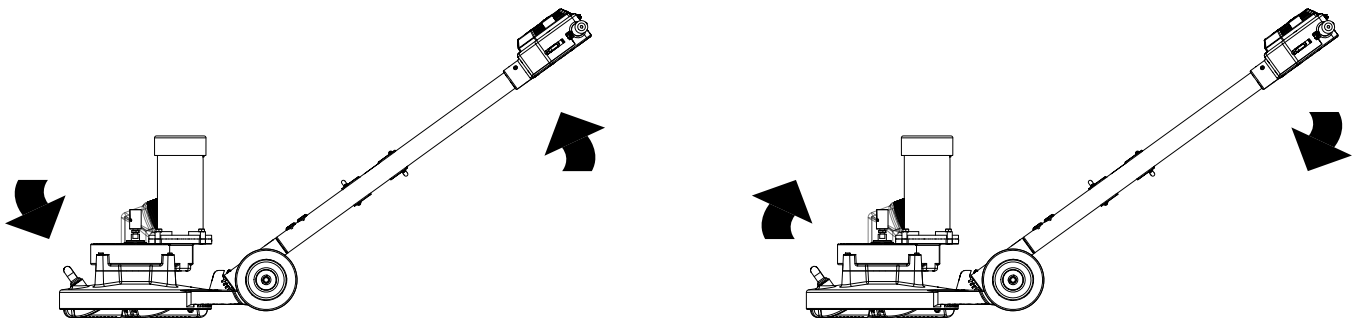

**CAUTION**

Tilting your TREX™ may result in carpet damage.



Your TREX™ maneuvers much like a floor machine. Slightly lift handle to move to the right. Press the handle down slightly to move to the left. Tilting your TREX™ may result in carpet damage. Remember to always keep TREX™ evenly balanced on the surface.

CORRECT CLEANING PATTERNS

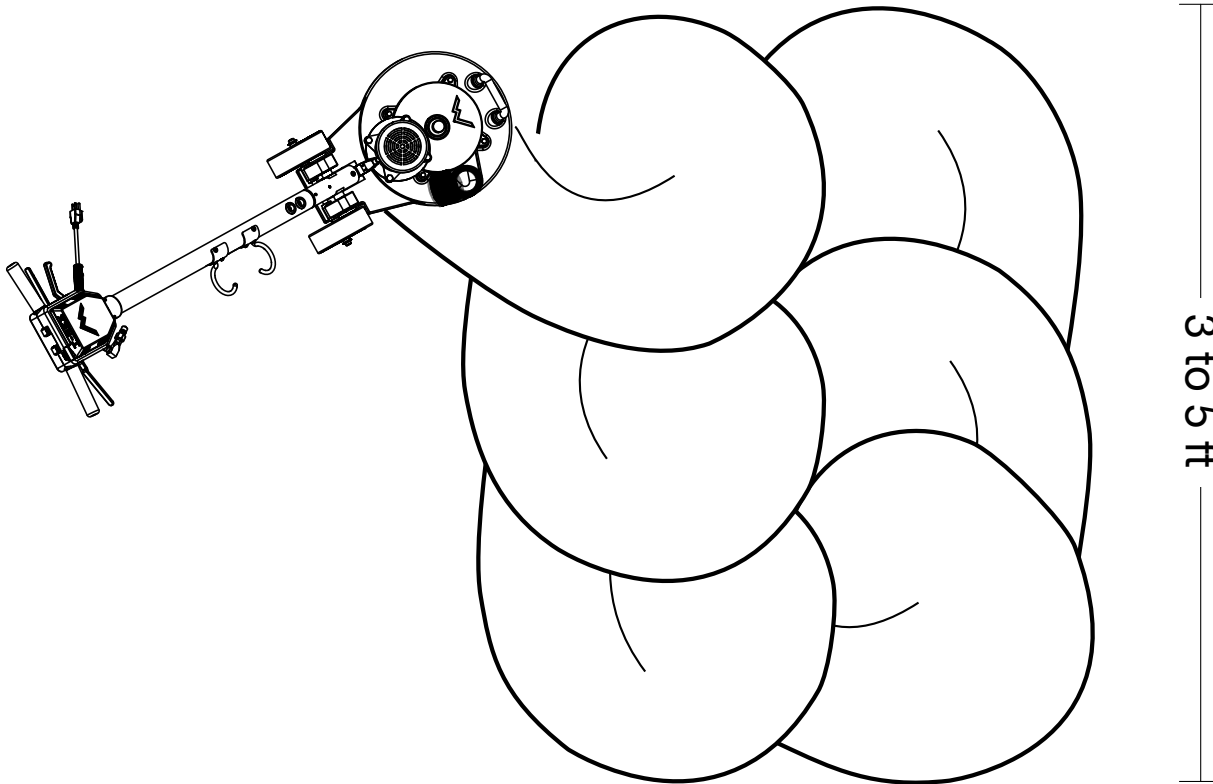
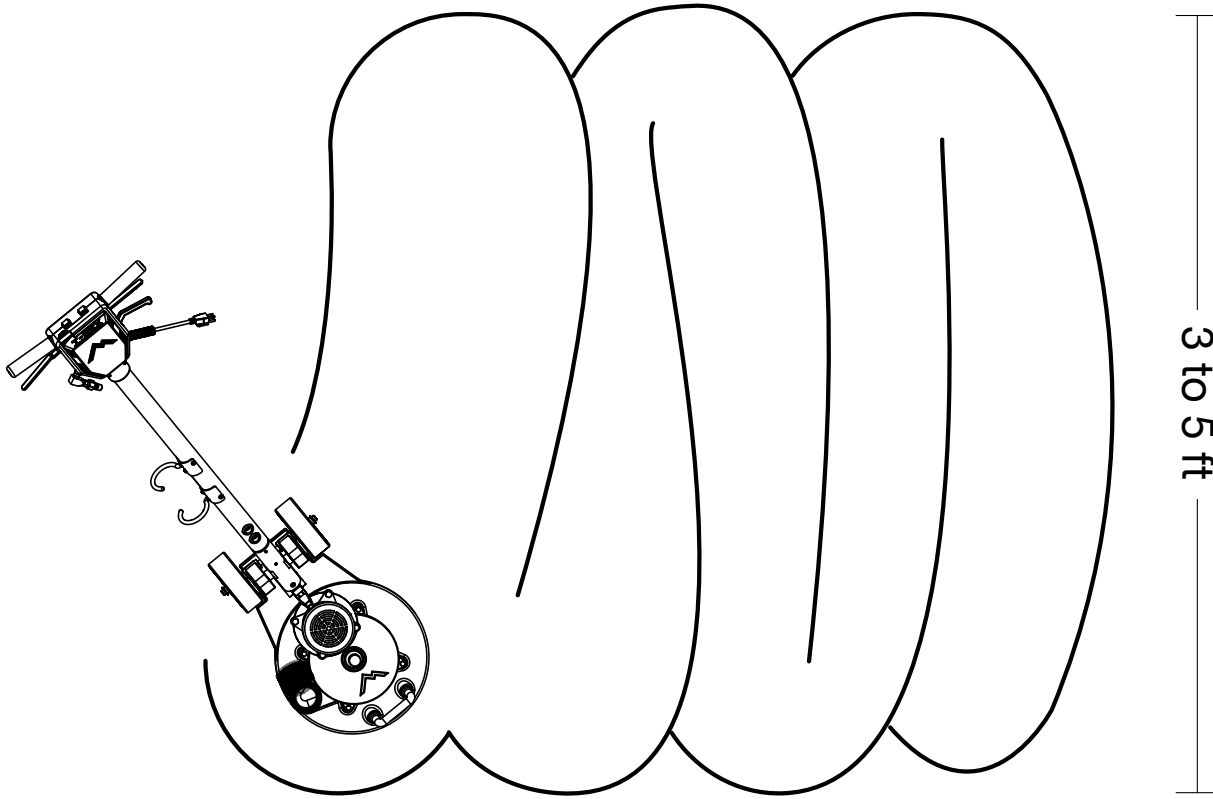

To get the best carpet cleaning results, move your TREX™ in an arc pattern or circular motion. To remove stubborn stains, try hovering the TREX™ over the stain.

# TREX™ PARTS & PRICING

ITEM NO.	PART NO.	DESCRIPTION	QTY.	MSRP	ITEM NO.	PART NO.	DESCRIPTION	QTY.	MSRP
1	H341	handle pivot, floor machine	1	\$74.99 ea	53	H159	cabie, handle adj, floor machine	1	\$6.99 ea
2	H089	axle, 9.63" x .50" dia	1	\$7.99 ea	54	H216	nut, lock, 1/4-20, nylon insert, s/s	1	\$0.99 ea
3	H267	pivot support, f-rex	2	\$40.99 ea	55	H458	nut, lock, 10-32, thin pattern	2	\$0.99 ea
4	H065	bushing, sleeve, 5/8 i.d. x 1.25" long	2	\$9.99 ea	56	P529	spacer, lever, handle adj.	1	\$1.99 ea
5	H066	bolt, shoulder 5/8" x 1.25 long, 1/2-13 thrd	2	\$14.99 ea	57	H257	lever, solution, T-REX	1	\$9.99 ea
6	H427	washer, wave	2	\$1.49 ea	58	H167	switch, floor machine	1	\$13.99 ea
7	H665	wheel, 6" dia, 2" width, 1/2 axle	2	\$24.99 ea	59	H127	bracket, mount, switch	1	\$0.99 ea
8	H219	cap, axle, 1/2"	2	\$0.99 ea	60	H640	washer, internal star, 3/8" zinc	1	\$0.99 ea
9	H157	spring, handle adjustment	1	\$5.99 ea	61	H384	washer, 3/8 flat, s/s	1	\$0.99 ea
10	H847	bushing, locking piston	1	\$17.99 ea	62	H263	lever, switch, T-REX	1	\$15.99 ea
11	H152	retaining ring, internal 1 1/2"	1	\$0.99 ea	63	G040	grip, handle, floor machine	2	\$1.99 ea
12	H844	locking piston, handle adj.	1	\$19.99 ea	64	P522	handle, back half, T-REX	2	\$0.99 ea
13	H148	washer, 5/16", narrow	7	\$0.99 ea	65	H261-B	handle, reinforcement, side, T-REX	2	\$10.00 ea
14	H843	locking arc, handle adj, floor machine	1	\$51.99 ea	66	H261-A	handle, reinforcement, center, T-REX	1	\$14.99 ea
15	H421	washer, 5/16" lock, s/s	10	\$0.99 ea	67	H222	screw, 10-32 x 1-1/4" phil pan head, s/s	2	\$0.99 ea
16	H151	bolt, 5/16-18 x 3/4" Long SHCS	10	\$0.99 ea	68	P541	lockout, floor machine	1	\$1.99 ea
17	H705	bolt, guide, locking piston	1	\$0.99 ea	69	H168	spring, lockout, floor machine	2	\$1.99 ea
18	A102	assembly, cleaning head, T-Rex	1	\$699.99 ea	70	H260	cover, switch box, T-REX	1	\$19.99 ea
19	H126	plate, seal, head/ bell housing	1	\$5.99 ea	71	G087	bumper w washer	2	\$0.99 ea
20	P516	bell housing and chasis, f-rex	1	\$39.99 ea	72	H017	screw, 10-32 x 1.5", FHSCS, s/s	2	\$0.99 ea
21	H768	bolt, 1/4-20 x 3/4" serrated hex flange, zinc	2	\$0.99 ea	73	H018	screw, 10-32 x 1/2", FHSCS, s/s	3	\$0.99 ea
22	H485	handle, breeze and dk	1	\$6.99 ea	74	H161	roll pin, 1 3/4" x 1/8"	2	\$0.99 ea
23	G023	o-ring, 8.5" o.d. x 1/8" width	1	\$0.99 ea	75	H160	spring, switch/lever	2	\$0.99 ea
24	A918	transmission, T-Rex	1	\$699.00 ea	76	H149	bolt, 5/16" shldr x 5/8" w/ 1/4-20 thrd	1	\$0.99 ea
25	B139	rotary union	1	\$159.99 ea	77	H839	lever, handle adj., floor machine	1	\$7.99 ea
26	P517	vacuum sight tube w/ 2" fw mpi Cuff-Lynx	1	\$31.99 ea	78	H144	strain relief, power cord, floor machine	1	\$6.99 ea
27	H230	screw, 10-32 x 1/2" phil pan head, s/s	7	\$0.99 ea	79	E584	pligtail, 15.5", black, 14/3 heavy jacket	1	\$11.99 ea
28	H882	screw, 8 x 3/4 phil pan head, type a, s/s	2	\$0.99 ea	80	H249B-ss	tube, f-rex	1	\$199.99 ea
29	P501	cover, controller board, f-rex	1	\$15.99 ea					
30	E382	pcb speed control, f-rex	1	\$165.99 ea					
31	H258	switch box, T-REX	1	\$25.99 ea					
32	P574	knob, clear plastic, f-rex potent	1	\$1.49 ea					
33	E363	potentiometer, slide	1	\$16.69 ea					
34	B101	qd, brass, 1/4" m	1	\$8.49 ea					
35	H462	housing, filter, 2 piece	1	\$2.99 ea					
36	G077	filter, cone	1	\$2.99 ea					
37	B237	needle valve, 1/4", T-Rex	1	\$99.99 ea					
38	B107	needle valve, 1/4" m, hex	1	\$3.19 ea					
39	B100A	swivel, high pressure, stainless steel	1	\$109.99 ea					
40	B130	45 deg, street elbow, brass, 1/4" male	1	\$5.49 ea					
41	B133-A	valve, brass, K, w/ trigger for wands	1	\$30.99 ea					
42	B103	elbow, brass, 90 deg, 1/4" mpt x 1/4" fpl	1	\$4.49 ea					
43	AH110	sol hose, 1/4" x 48" (OAL)	1	\$48.99 ea					
44	H136	Cuff-Lynx, 2" hose x 2" male swivel Cuff-Lynx	1	\$3.99 ea					
45	C311	motor, dc, 1/2hp	1	\$569.99 ea					
46	H054	bolt, 2/8-16 x 1-1/4", hex head	4	\$3.99 ea					
47	H169	bolt, 1/4-20 x 2", hex head	4	\$3.99 ea					
48	H215	nut, hex, 1/4-20 s/s	1	\$0.99 ea					
49	H164	grommet, floor machine, 5/8" ID	2	\$1.99 ea					
50	E550	power cord, female pigtail, 37', 16/3	1	\$11.49 ea					
51	H047	screw, 1/4-20 x 1/2", button, s/s, blk oxide	10	\$0.99 ea					
52	H247A	hook, hose restraint, T-REX	2	\$14.99 ea					

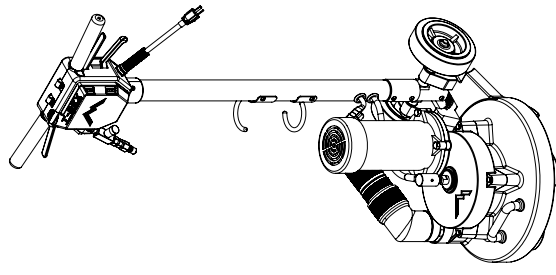

ITEMS NOT SHOWN

PART NO.	DESCRIPTION	QTY.	MSRP
ADM-TREX	manual, T-Rex	1	N/A
G014	seal, felt, 1/2" thick	2	\$10.99 ea
H051	wrench, flat, 5/8"	1	\$3.99 ea
H053	tool, starremoval	1	\$10.99 ea
E617A	25' extension cord, 16/3, black	1	\$36.99 ea
P576	star protector	1	\$24.99 ea
P588A	cord lock, S-type	1	\$8.99 ea
PH648	lubricant, teflon oil, tube	1	\$9.99 ea

mytee PRODUCTS, INC.  
886-575-1391

TITILE: T-REX SS

DATE: 8/2013

NAME: M.L.BORG

DRAWN: M.L.BORG

CHECKED:

PROPERTY AND/OR ESSENTIAL

THIS DRAWING IS FOR INFORMATION ONLY. IT IS NOT TO BE USED FOR THE PURCHASE OF PARTS OR TO BE USED FOR THE REPAIR OF EQUIPMENT WITHOUT THE WRITTEN PERMISSION OF mytee PRODUCTS, INC.

SCALE: 1:24

SIZE DWG. NO. C T-Rex (SS) OD

REV. SHEET 1 OF 3

Order parts at: [http://www.mytee.com/products/t-rex/#.UKLKleOe\\_-l](http://www.mytee.com/products/t-rex/#.UKLKleOe_-l)

Part prices are subject to change.

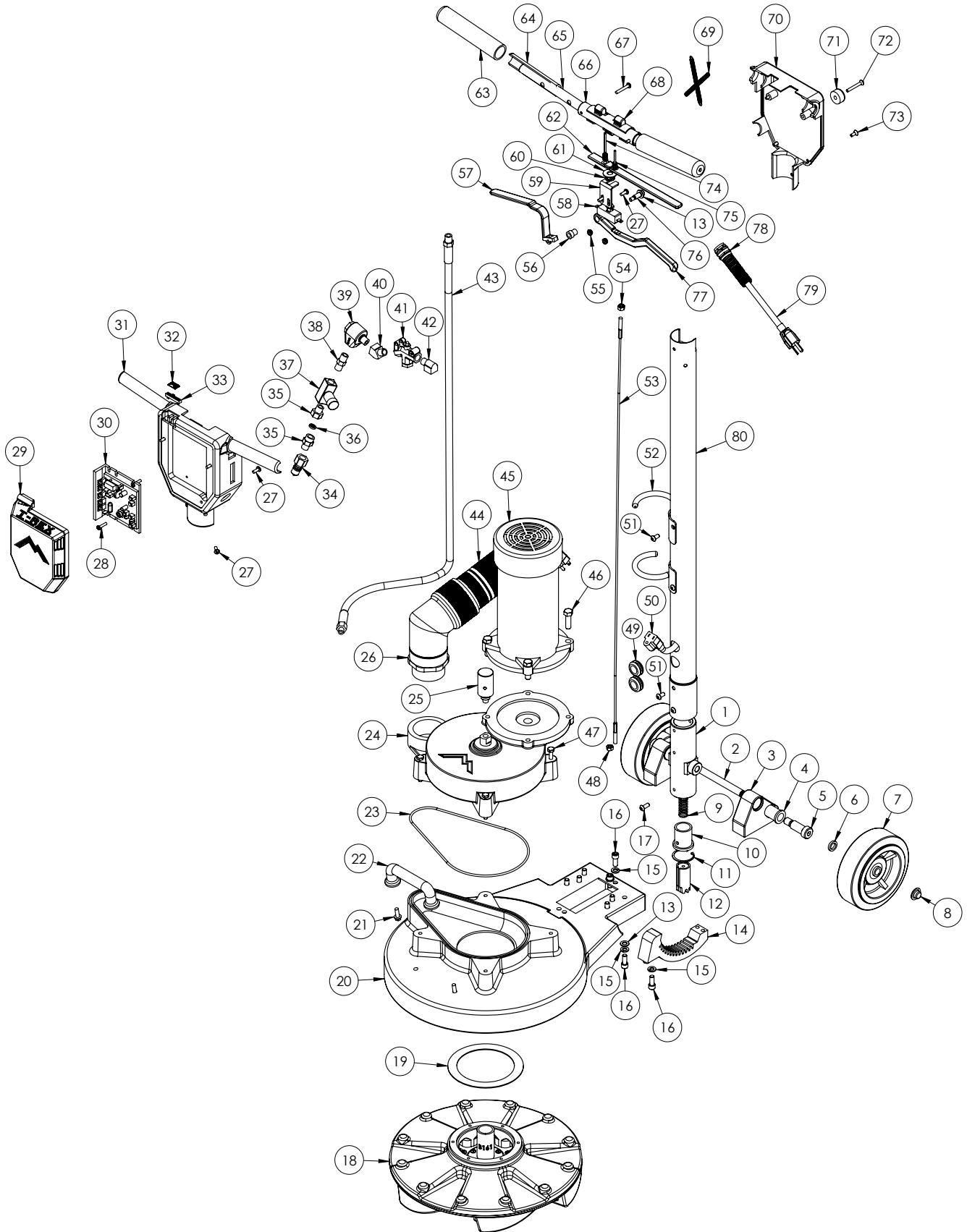

# TREX™ WIRING DIAGRAM

## T-REX Wire Schematic

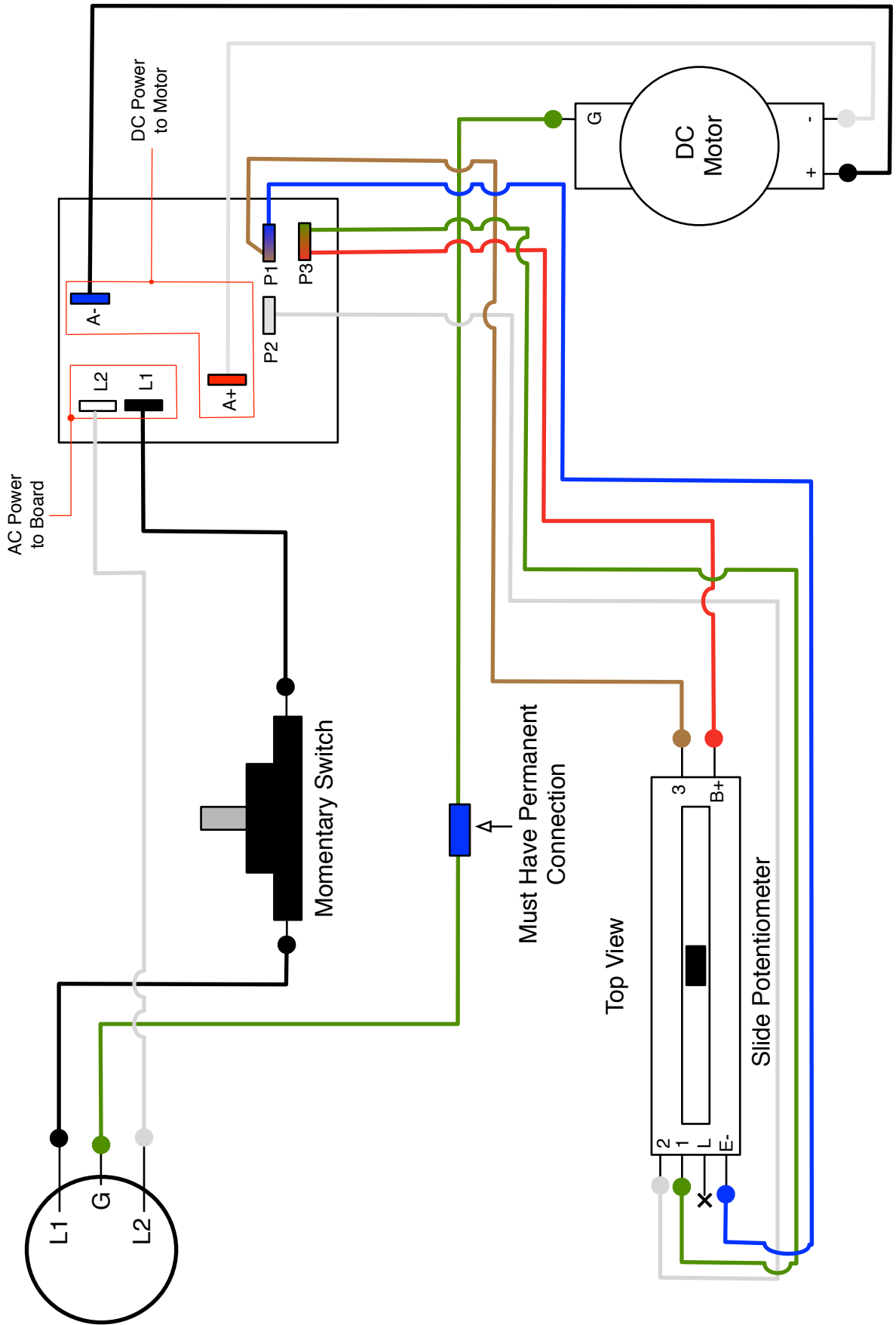

Note: X indicates non use

## Dear Customer:

Congratulations on the purchase of your new TREX™ total rotary extractor. As technology continues to develop you can work confidently knowing that both Mytee Products Inc. and its employees are equally dedicated to developing with the industry and its advances.

Like any other piece of machinery or technology, the TREX™ also requires the proper maintenance and care to keep the product working over extended use. Neglecting your machine, abusing it or not operating it properly can void its warranty and prevent the machine from performing to the quality and standard you'd expect out of the Mytee Products Inc. line.

If you have any warranty concerns or questions, please review this manual thoroughly or do not hesitate to contact your distributor. If there are questions regarding maintenance, replacement or ordering parts please contact an authorized Mytee Products Inc. Service Center. To see an updated list please visit our website at <http://www.mytee.com/support/service-centers/>

Before using your Mytee Product, please read this manually thoroughly. Sincerely,  
Mytee Customer Care Dept.

## Grounding Instructions

This machine must be grounded. If it should malfunction or breakdown, grounding provides a path of least resistance for electrical shock. This machine is equipped with a cord having an equipment-grounding conductor and grounding plug. The plug must be plugged into an appropriate outlet that is properly installed in accordance with all local code and ordinances. Do not remove ground pin; if missing, replace plug before use.



### DANGER

Improper installation of the equipment-grounding conductor can result in a risk of electric shock. Be sure to check with a qualified electrician or service person if you are in doubt as to whether the outlet is properly grounded. If the plug will not fit in the outlet do not modify either the plug nor the machine's cord, instead have a proper outlet installed by a qualified technician.

This machine is for use on a nominal 120-volt circuit and with a grounding plug similar to the one in Figure 1 below. If a proper outlet is not available, follow the illustrations of Figure 2 & 3 to install a temporary-grounding plug. This temporary work-around should be used only until a proper outlet (Figure 1) can be installed by a qualified electrician. When and if this type of adapter is employed, screw the adapter's extended tab into place with a metal screw. However, grounding adapters are not approved for use in Canada.

Again, be sure to check the grounding pin for damages and replace if necessary.

The Green, or Green-Yellow, wire in the cord is the grounding wire. When replacing a plug, this wire must be attached to only the grounding pin.

DO NOT use extension cords.

### Please Note for America use only

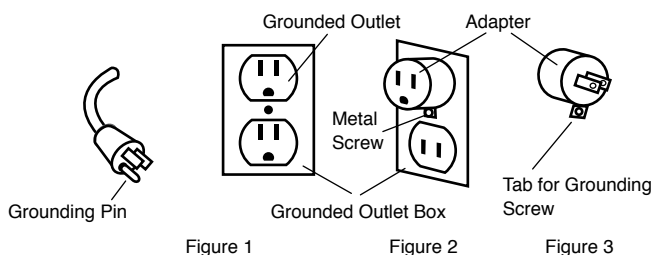

## Parts and Service

Please contact a Mytee service personnel or Mytee authorized Service Center using Mytee original replacement parts and accessories for repairs are needing to be performed. When and if calling Mytee for support, please have your Model and Serial Number available for faster assistance.

## Name Plate

The Model and Serial Number are located on the switch box of the machine near the power plugs and will be required for ordering replacement parts. You can use the space provided on the front of this manual to note down both for future referencing.

## Unpacking the Machine

When your new machine is delivered, please carefully inspect both the shipping carton and the machine for damages. If damage is evident, save both the shipping carton and machine so that the delivering carrier can inspect it. Contact the carrier immediately to file a freight claim if there has been any damage.

## Caution and Warnings

### Symbols

Mytee uses the symbols below to signal potentially dangerous conditions. Always read this information carefully and take the necessary steps to protect personnel and property.



### DANGER

Is used to warn of immediate hazards that will cause severe personal injury or death.



### WARNING

Is used to call attention to a situation that could cause severe personal injury.



### CAUTION

Is used to call attention to a situation that could cause minor personal injury or damage to the machine or other property. When using an electrical appliance, basic precautions should always be followed, including the following: Read all instructions before using this machine. This product is intended for commercial use only.



### WARNING

To reduce the risk of fire, electrical shock, or injury:

1. Read all instructions before using equipment.
2. Use only as described in this manual. Use only manufacturer's recommended attachments.
3. Always unplug power cord from electrical outlet before attempting any adjustments or repairs.
4. Do not unplug by pulling on cord. To unplug, grasp the plug, not the cord.
5. Do not pull or carry by cord. Do not close a door on cord or pull cord around sharp edges or corners.
6. Do not run appliance over cord. Keep cord away from heated surfaces.
7. Do not use with damaged cord or plug. If cord is damaged, repair immediately.
8. Do not use outdoors or on wet surfaces and or standing water.
9. Always unplug or disconnect the appliance from power supply when not in use.
10. Do not allow to be used as a toy. Close attention is necessary when used by or near children.
11. Do not use in areas where flammable or combustible material may be present.
12. Do not leave the unit exposed to harsh weather elements. Temperatures below freezing may damage components and void warranty.
13. Use only the appropriate handles to move and lift unit. Do not use any other parts of this machine for this purpose.
14. Keep hair, loose clothing, fingers, and all parts of the body away from



# GENERAL INFORMATION

all openings and moving parts.

15. Use extra care when using on stairs.
16. To reduce the risk of fire or electric shock, do not use this machine with a solid-state speed control device.
17. The voltage and frequency indicated on the name plate must correspond to the wall receptacle supply voltage.
18. When cleaning and servicing the machine, local or national regulations may apply to the safe disposal of liquids which may contain: chemicals, grease, oil, acid, alkalines, or other dangerous liquids.
19. Do not leave operating unattended.

## Preparation

1. Remove furniture and other items from the area you are going to clean.
2. Vacuum carpet and upholstery, and remove debris.
3. Protect cabinets, walls and painted surfaces with drop cloths or plastic.
4. Inspect power cords for damages.
5. Remove protective wrapping from wheels.
6. Attach the cleaning head at the base of the TREX™. First, lean the TREX™ back and rest it on the handle. Second, thread the head onto the exposed shaft in a counterclockwise direction.
7. Attach vacuum and solution hoses to unit.
8. Start extractor per operating instructions for unit.

## Operating Instructions

**Step 1 – Adjust the handle.** To do so, pull back on handle adjustment lever and move the handle up or down to desired operating position. Most users find that they have better control and less fatigue if the handle is in a low position, just around the hip line.

**Step 2 – Controlling the motor and spray.** There are triggers located on both sides of the handle. The trigger on the left controls the solution flow. Activating this trigger will lay down spray through the jets on the star. The pressure of the spray is determined by the type of pump you have hooked up, either on your portable extractor or truckmount.

The trigger on the right hand side controls the motor. To activate the motor, you must first push down the safety lockout, and then pull on the trigger. **PLEASE NOTE:** Be sure that you have good control of the unit when you activate the motor, as it will move quickly when started.

The airflow of the unit is controlled by the vacuum source you have hooked into the machine. The air flows constantly during operation.

**Step 3 – Maneuvering the unit.** The TREX's™ movement is controlled by moving the handle up or down (similar to a floor machine). To move the machine to the right, lift the handle slightly. To move to the left, lower the handle slightly. The more you lift or lower the handle, the faster the machine will move.

**CAUTION –** Do not tilt the machine on its side during use! Doing so may result in the ejection of your glides, damage to the star, damage to property, and/or injury.

To move the machine forward or backward, position the machine so the head is “hovering” over one spot, and then push or pull forward or back.

**CAUTION –** Do not operate the machine on dry carpets. The friction caused by the head movement may cause fiber damage to the carpet.

## After Use

1. When machine is transported or stored, apply the head protector.
2. Blow all air out of unit prior to storing with compressed air. Storing the machine with fluid in the lines can result in serious damage if the unit freezes.
3. Store machine in a dry area in the upright position

**ATTENTION:** Do not expose to rain. Store indoors.

**ATTENTION:** If storing machine in freezing temperatures, be sure that machine and solution system are completely drained and dry.

## Maintenance Schedule

Maintenance item	Daily	Once a week
Inspect cords and hoses for breaks or tears. Replace any damaged items.	x	
Visually inspect machine for damage to cleaning heads, etc. Repair as necessary.	x	
Clean machine with an all purpose cleaner and damp cloth.	x	
Remove the in-line solution filter screen and rinse under water to remove debris.	x	
Check the spray jets for even spray. If uneven, the jet may be clogged and need cleaning. If clogged, remove spray tips and soak them in a recommended liquid neutralizer for up to six hours. To remove spray tip, twist spray tip body counterclockwise. Do not use pointed objects to unplug tips, damage will occur.	x	
Remove the cleaning head. It unscrews in a clockwise direction when looking at the underside of the machine. Once you have loosened it, the star should turn freely in your hands. Wash the cleaning head and shroud thoroughly, being sure not to wet the motor assembly. Clean any lint buildup from the star and vacuum heads.		x
Clean off any debris that is on the shaft of the motor or the hub of the star. If not cleaned regularly, debris here can damage the oil seal on the gearbox, and result in loss of oil.		x
<b>WARNING: Operating the unit without the gearbox properly lubricated can result in damage.</b>		
Lubricate the felt vacuum seal with 30W SAE motor oil.		x
Coat the shaft with WD40 or a similar lubricant.		x
<b>WARNING: When reinstalling the vacuum star, make sure that it spins freely. If it begins to require pressure, unscrew it and clean threads. Dirt or grit can block the threads, and if you continue to tighten, may lock the star on the motor shaft.</b>		

## Trouble Shooting

### Motor will not start.

1. Not plugged in - plug machine in proper outlet.
2. Circuit breaker has popped - reset circuit breaker. Make sure no other items are running on the same circuit as machine. Outlet must be a 15-amp circuit.
3. Switch is bad - install replacement switch.
4. Motor is bad - install replacement motor.

### Star will not turn.

1. Motor is not operating (see above).
2. Star is jammed - remove star. Check for obstructions. Clean threads on shaft and hub.

### No solution spray at jets.

1. Jet is clogged - clean jet and flush clean.
2. Filters are clogged - remove filter and rinse clean with water.



3. Trigger valve has failed - replace valve.
4. Pump not operating in extractor - check pump.
5. No solution in extractor - refill.

#### **No vacuum suction at slots.**

1. A hose is blocked - check and clear all hoses.
2. Hose between head and handle is kinked - unkink hoses.
3. A vacuum hose has developed a leak or hole - replace hose.

#### **Machine vibrates during use.**

1. The star is bent - examine star and realign or replace.

#### **TIPS**

**WARNING:** Flammable materials or reactive metals can cause an explosion or fire.

Do not pick up.

Do not operate the machine over floor moldings. Damage to the molding and the head will occur.

Do not operate the machine on concrete or hardwood floors. The machine is designed for carpet use only. Use on other surfaces will cause damage to the unit.

Do not operate your machine over loose or unraveled carpet seams. The cleaning head may grab the loose piece and cause further damage.

Do not clean over the edge of loose carpet. Extraction heads will catch the carpet edge.

Work away from outlet and power cord to prevent cord damage.

During cleaning of plush carpet, you may notice some loose yarns being thrown from the sides of the extraction head. This is normal.

On carpets that have delaminated (the face has come loose from the backing), this machine may cause further delamination. When in doubt, do not use the unit.

The machine will leave carpet with "swirl marks" from the cleaning process. These should be brushed out at the end of cleaning with a carpet rake or brush.

To clean heavily soiled areas, repeat cleaning path from different direction. After cleaning, relieve water pressure from tool before disconnecting hose.

Squeeze trigger for five seconds after turning main power switch off.

Always hook up solution and vacuum hoses to the machine **BEFORE** turning on pumps or motors. Solution lines will be difficult, if not impossible to plug in while pump is pressurized.

#### **FAQs**

Q: How much does the TREX™ weigh?

A: Machine weighs 65 lbs., cleaning head is 18 lbs.

Q: What comes standard with TREX™?

A: A916 - Head protector, G014 - Felt Ring Seal, H053 - Head Removal Tool, H051 - 5/8" Flat Wrench, H061 - 2" x 25" Vacuum Hose, A917 - Vacuum Relief, E617A - 25' Power Cord.

Q: Is there anything I can do to increase the expected life of my TREX™?

A: Regular cleaning and maintenance of the entire unit.

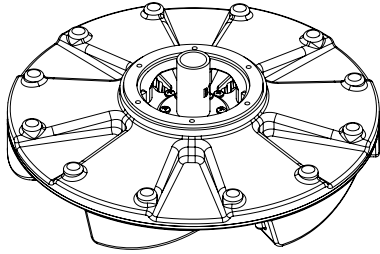

A102 - Cleaning Head

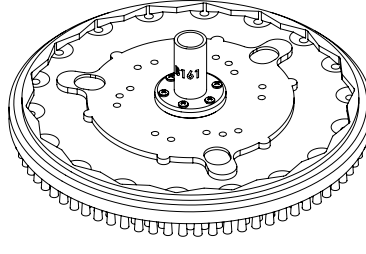

A103 - TREX™ Brush

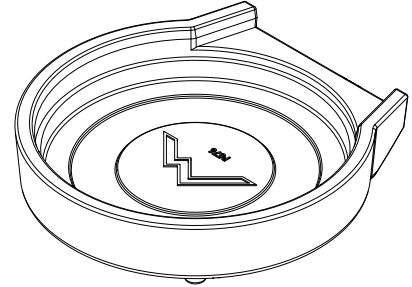

A916 - Head Protector

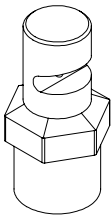

B183 - TREX™ Jet

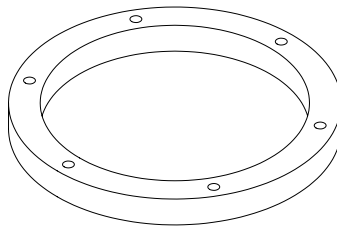

G014 - Felt Ring Seal

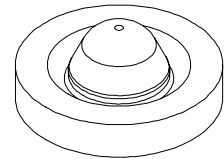

G077 - TREX™ Cone Filter

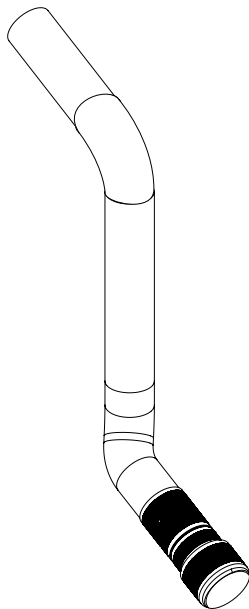

#### - Attachable Lead Hose with Cuff-Lynx™

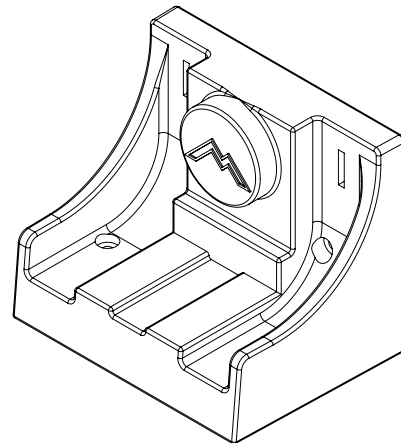

P577 - Docking Station

# NOTES

# NOTES



Mytee Products Inc.  
13655 Stowe Dr.  
Poway, Ca. 92064  
[www.mytee.com](http://www.mytee.com)  
FX 858.679.7814

© 2015 Mytee Products Inc.  
Printed in the U.S.A.